

COMEPI safety switches are conceived and manufactured according to the international IEC standards and to the European EN standards. These devices are suitable for machines where hazardous conditions continue after the stop signal and they can be used to manufacture safety systems in compliance with standard ISO14119. Since their purpose is to protect operators, any unsuitable installation or tampering with the devices can injure people seriously. Therefore, the installation must be carried out according to the standards in force and by authorized personnel only. We also recommend checking the switch before starting the machine and checking periodically the correct device operation.

The aim of this document is to give information for a correct installation of the device, including a suitable connection and a safe application according to the standards in force.

#### Choice of the most suitable operating principle

The device can be bought in two different versions, with a different locked actuator. The M version is based on the actuator lock with deenergized solenoid. The E version includes the actuator lock with energized solenoid. In the M version the lock is preserved and it is impossible to reach dangerous parts even in case of a voltage drop. On the contrary, the E version allows reaching immediately the dangerous area even if the power is switched off suddenly. A serious risk assessment must be carried out to choose the right device. If the two models are used without lock function, they can be used interchangeably.

#### Device start up

The FEP-RFID device is supplied with a coded actuator with RFID technology. The actuator supplied has been coupled to the device by the manufacturer, so it is ready to be used. The actuator to use is univocal, it is possible to couple other devices, but each new actuator coupled replaces the previous one. The actuating head cannot be disassembled by the user, so we recommend choosing the right one before buying the product. The actuator supplied is a high coding level actuator according to standard EN ISO 14119, so the measures against any easy bypass strategy for low coding level devices are not necessary. In any case make sure the device is installed in places that cannot be reached easily by unauthorized personnel.

#### Coupling of a new actuator

If the actuator is broken, it can be replaced with original COMEPI spare parts. To couple the new actuator remove the FEP device cover and insert the actuator into the slot so that the TAG area is coupled to the lower part of the head. Use a pin to reach the coupling button with a hole on the internal cover. Hold down till the three signalling LEDs flash green simultaneously. The new actuator is coupled and ready to be used. The old actuator has been replaced and its TAG is no longer recognized by the device unless it is coupled again. Warning: the actuator TAG and the device antenna cannot be removed from their seat, since they are sealed so that they cannot be bypassed easily.

#### Device wiring

The device can be supplied with an M12 connector, already connected by the manufacturer, or with a threaded hole for cable gland M20x1.5. In the second case the device must be wired using the terminals supplied to the user. Do not drill the device to wire it, but use only the available hole. Wire the device according to the operating diagrams shown below and using conductors with a size between 0.34mm<sup>2</sup> and 1.5mm<sup>2</sup>. It is advisable to tighten the terminals with a torque equal to 0.5 Nm, with a maximum of 0.8 Nm. Any incorrect wiring as well as any wiring carried out using unsuitable conductors can seriously compromise the operation of the device itself, jeopardizing the right safety functions. To reach the terminal area remove the main cover, fixed with four screws. Never remove the secondary internal cover: if this prescription is not complied with, the correct operation of the device can be compromised and its safety functions can be prevented. Close again the cover with a tightening torque between 0.5 Nm and 0.8 Nm. Any incorrect cover closing can compromise the IP degree of protection indicated by the manufacturer. Use only cable glands guaranteed to ensure the IP degree of protection required by the application.

#### Fastening of the device

The device must be fastened securely to the structure, using 4 M5 screws whose length is not lower than 45mm. Strictly avoid fastening the device using less than four screws. Any incorrect fastening can compromise the right safety functions. The screws used must bear a tractive force of at least 1200N, otherwise the lock is not guaranteed. Tighten the screws with a torque between 2 and 3 Nm. We recommend using screws that cannot be easily tampered with, so that their fastening cannot be bypassed by unauthorized personnel. We also recommend fastening the device in the high part of the structure, to prevent dirt and dust from compromising its operation. The actuator must be fastened to the protection in such a way that it cannot be removed, as prescribed by standard EN ISO 14119. The actuator must be fixed with four M5 screws with a length of at least 20mm. The device cannot be fixed using a lower number of screws. The screws must bear a tractive force of at least 1200N, otherwise the

device lock function is not guaranteed. Tighten the actuator screws with a torque between 2 and 3 Nm. The device and the actuator must be correctly aligned after being fixed. Although the actuator is adjustable, too much misalignment can cause mechanical problems and break the device itself. Adjust the actuator manually, without using any tool that could break or damage it. Check periodically the correct alignment of the actuator with the device. If the actuator breaks, replace it. In case the device is damaged, replace it completely. Do not use the limit switch as mechanical lock.

#### Auxiliary release with safety screw

The device has an auxiliary release with safety screw. The arrow on the cover indicates the device status. The release is enabled by loosening the safety screw and by turning 180°. The device is supplied with the safety screw sealed with paint in order to prevent any misuse of the release function.



#### Connections

The safe outputs of the device must be connected to a safety module or to a safety PLC to be correctly controlled and to ensure the right operation of the safety system. This device ensures the safety of people and of the equipment, so it is strictly forbidden to bypass its functions by avoiding its correct installation. Remember that the system safety category does not depend exclusively on the device, but also on the connections and on the other external devices involved in safety. Before connecting the device make sure it is intact in all its parts, as well as the cables used for connecting. Avoid bending too much the conductors to reduce the risk of power failures or short circuits. Before starting the device check the machine is in compliance with the standards in force and with the requirements of the EMC Directive. Do not start it in safety systems that do not comply with the requirements of the standards in force. In case of problems to understand this document or the device operation, always contact COMEPI technical support.

#### Maintenance

Do not disassemble and do not try to repair the device. In case of damage or failure replace the whole device. The sequence of the functional tests the device will be subject to are under the installer's responsibility. We recommend checking, according to the timing arrangements, the following functions: ① Lock the protection and start the machine; it must be impossible to open the protection ② Stop the machine and open the protection; the machine must not start ③ When the protection is closed, without enabling the device lock, the machine must not start ④ Check visually the device status ⑤ Check visually the actuator status ⑥ Check that the device has not exceeded its service life according to the supposed operating frequency or to a meter. In any case the device must be replaced after 20 years of service.

#### Other installation precautions

Before starting the device check the correct operation of the safety system - Periodically check the correct operation of the device as specified in the maintenance section - The installation must be carried out only by authorized and qualified personnel - The use of the device must be limited to the applications in compliance with the regulatory requirements - The device installation and the safety system design must be carried out only by people who know the regulatory references - The device installation and the safety system design must be carried out in compliance with the standards in force - In case of doubts or of special applications contact COMEPI technical support - Enclose this document to the technical file and to the operating instructions of the machine where the device is installed - Make always available this document for the personnel who works on the machine where the device is installed - During installation and operation, prevent dust and dirt from entering the slot when the drive key is not inserted - Before any painting work cover the slots and the identification label - Do not remove the identification label, otherwise the compliance with the EC Declaration connected to the device itself may be compromised - Do not install if there are strong vibrations; All shocks and vibrations can prevent the correct operation of the switch - Do not modify the device as it is - Do not disassemble and reassemble the actuating head: if this operation is carried out incorrectly, it could cause malfunction - Do not remove the secondary internal cover - Do not disassemble and reassemble the microswitch: any approximate positioning could prevent the correct operation. Use only suitable actuators supplied by COMEPI and concerning the model used, otherwise safety is not guaranteed - Install the actuator so that it does not injure the operator when the door is open - Replace the device after exceeding the mechanical durability limit - During wiring keep the load below the value of the category of use - Connect the safety contacts to a protection fuse - Before reaching the switch contacts make sure to disconnect the power supply from the device - Tighten the screws with the torques indicated in this document - The end-of-life device must be correctly disposed of, according to the laws of the country where it is disposed of.

**Limits of use**

Use the switch in compliance with the standards in force, according to the instructions and using it according to its limits of operation. In case of improper use, non-compliance with the instructions, assembly and maintenance carried out by unauthorized or unskilled staff and failure to perform the functional tests, the manufacturer is not liable at all. Do not use the device separately to ensure safety in those areas where the operator can enter with all his body within the perimeter. Any unintentional closing of the protection behind the operator could cause dangerous situations for the operator himself. Do not use in places with continuous changes in temperature, that could cause condensation inside the device. Do not install in areas with dust or dirt that could compromise the device operation. Do not install in places with powders or flammable gases. Do not use outside the temperature limits expected for operation. Do not use in places where ice sleeves can form on the device or on the actuator. Do not use with very corrosive chemical agents, that can damage the internal mechanisms and the device gaskets.

**The device complies with the requirements of the following Directives:**

Low Voltage Directive 2014/35/EU

According to standard EN 60947-5-1

Machinery Directive 2006/42/EC

According to standard EN ISO 14119

Directive RoHS 2002/95/EC

FCC Part 15 (see recommendations at page 4)

**General technical data**

Housing	Housing in engineering plastic	Maximum clearance of the locked actuator	4.1 mm
Room temperature during operation	-20°C ... +55°C	Cable inlet	A threaded inlet M20x1.5
Environmental designation	Type-1 enclosure	Prewired version	8-pole M12x1 male connector
Protection against electrical shock	Class II (thermoplastic housing)	Mechanical duration	1 million operations
IP Degree of protection	IP65	B10d	4 million operations
Maximum actuating frequency	600 cycles/hour	Maximum period of use	20 years
Maximum actuating speed	20 m/min	SIL level according to EN 62061	For applications up to SIL3
Weight	0.5 Kg	PL level according to EN ISO 13849-1	For applications up to PLe
Actuation force	5 N	Type of interlock according to EN ISO 14119	Type 4
Extraction force	30 N	Coding level according to EN 14119	High
Maximum holding force Fzh	1200 N	Type of emergency release	Manual
Tensile strength	1560 N	Device supply	24Vcc (+/-10%)

**Allowed power supply**

Power supply range	Device status	Measures
21.6V < V < 26.4V	Normal operation	None
16.8V < V < 21.6V 26.4V < V > 28V	Alarm mode	LED indication. Adjust as soon as possible the power supply. The functions continue to be ensured.
V < 16.8V V > 28V	Device disabled	The device is disabled to avoid dangerous situations not signalled. Warning: The Electric Lock model allows reaching immediately the protected area when there is no power supply.
Solenoid supply I < 50mA I > 250mA	Device disabled	The abnormal current on the solenoid can indicate an incorrect supply or an internal failure. The device is disabled to avoid any dangerous situation not signalled. Warning: The Electric Lock model allows reaching immediately the protected area when there is no power supply.

**Operating conditions and LED diagnostics**

Index	Actuator status	Power supply	Lock control	LED PWR	LED LOCK	LED KEY	Status 21-22 & 41-42	Status A1-A2
COND.01	Key not inserted	21.6V < V < 26.4V	ON or OFF	Red	Off	Off	Open + Open	Open
COND.02	Key inserted and recognized	21.6V < V < 26.4V	OFF	Red	Off	Green	Open + Open	Closed
COND.03	Key inserted and recognized	21.6V < V < 26.4V	ON	Red	Red	Green	Closed + Closed	Closed
COND.04	Key inserted and not recognized	21.6V < V < 26.4V	ON or OFF	Red	Off	Red	Open + Open	Open
COND.05	Key inserted and RFID absence	21.6V < V < 26.4V	OFF	Red	Off	Blinking red	Open + Open	Open
COND.06	Key inserted and recognized, subsequent RFID loss	21.6V < V < 26.4V	OFF	Red	Off	Blinking red	Open + Open	Open

**Certifications**

cULus according to standard UL508 – CB according to EN 60947-5-1 – FCC ID Number 2AP8TCMP9LRF (for the whole list of certified products contact COMEDI technical support)

**Examples of application and operation**

This kind of device is usually used to ensure the operator’s safety while using machines where a dangerous condition can continue even after the machine is stopped, for instance due to the inertia of mechanical parts that are moving, or to the presence of warmed up or pressurized parts. If this device is used separately, it is not suitable for machines where an operator can enter physically an enclosed area, since the enclosure could close accidentally after the operator has entered it. To test the correct device operation, check the right insertion of the actuator into the head slot and close the protection by starting the machine. In these conditions it must be impossible to open the protection. On the contrary when the machine is stopped and the protection is disabled the machine must not start.

**Safety warnings**

Safety switches protect operators. Any unsuitable installation, as well as the device tampering and the tampering of the safety system connected to it, can cause serious dangerous situations. The device must in no way be bypassed or tampered with. To prevent any easy tampering the installer should assemble the device in a place difficult to be reached by unauthorized staff, using if necessary physical obstacles and measures to make it difficult to tamper with the device.

COND.07	Key inserted and recognized, subsequent RFID loss	$21.6V < V < 26.4V$	ON	Red	Red	Blinking red	Close + Open	Open
COND.08	Key inserted and recognized	$21.6V < V < 26.4V$ With current: $I < 50mA$ $I > 250mA$	ON	Red	Blinking red	Green	Close + Close (BM) Open + Open (BE)	Closed
COND.09	Key not inserted	$16.8V < V < 21.6V$ $26.4V < V > 28V$	ON or OFF	Blinking red	Off	Off	Open + Open	Open
COND.10	Key inserted and recognized	$16.8V < V < 21.6V$ $26.4V < V > 28V$	OFF	Blinking red	Off	Green	Open + Open	Closed
COND.11	Key inserted and recognized	$16.8V < V < 21.6V$ $26.4V < V > 28V$	ON	Blinking red	Red	Green	Close + Close	Closed
COND.12	Any	$V < 16.8V$ $V > 28V$	On or OFF	Blinking red	Blinking red	Blinking red	Close + Close (BM) Open + Open (BE)	Open
COND.13	Key inserted, coupling in progress	$21.6V < V < 26.4V$	ON or OFF	Red	Off	Blinking green	Open + Open	Open

**Problem Solving**

Condition	Problem solution – Try with the solutions listed in the order described
COND.04	<ol style="list-style-type: none"> <li>1) Make sure the actuator inserted is the correct one. The actuator-device coupling is univocal</li> <li>2) Couple the actuator if not coupled yet</li> <li>3) Replace the key and repeat the procedure</li> <li>4) Replace the device and/or contact the technical support if the problem persists</li> </ol>
COND.05 COND.06	<ol style="list-style-type: none"> <li>1) Check the actuator is still present, mechanically intact and correctly positioned</li> <li>2) Replace the key and couple again</li> <li>3) Replace the device and/or contact the technical support if the problem persists</li> </ol>
COND.09 COND.10 COND.11	<ol style="list-style-type: none"> <li>1) Restore the correct device supply</li> <li>2) Replace the device if the problem persists</li> </ol>
COND.08 COND.12	<ol style="list-style-type: none"> <li>1) Restore the correct device supply</li> <li>2) Replace the device if the problem persists</li> </ol> <p><b>NOTE</b> if the problem is solved after point 1, check the device has not been damaged during the maintenance cycle</p>

**Wiring diagram of the device**

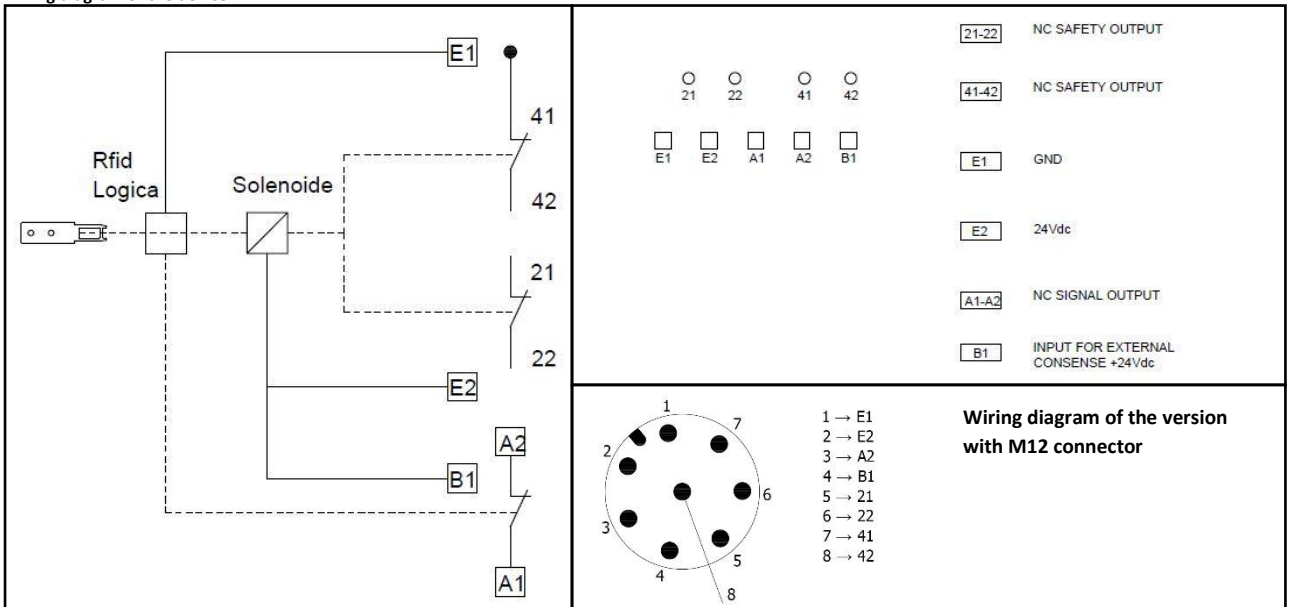

**Technical data of the version with 8-pole M12 connector**

Insulation voltage $U_i$	30Vcc	Impulse voltage $U_{imp}$	0.8kV
Operating current $U_e$	Contacts 21-22 and 41-42		2A (24Vcc)
Thread	M12x1	Tightening torque	0.6Nm

**Connection diagram of the device – Application example with safety module series MS1A31**

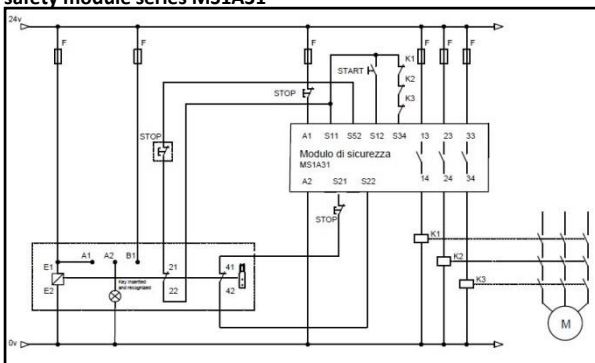

**Product working logic**

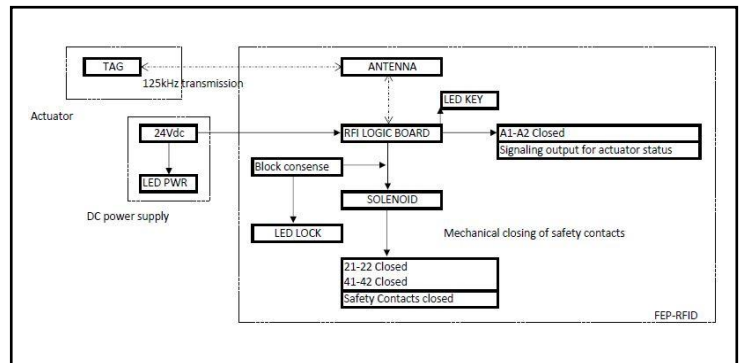

**Overall dimensions of the device**

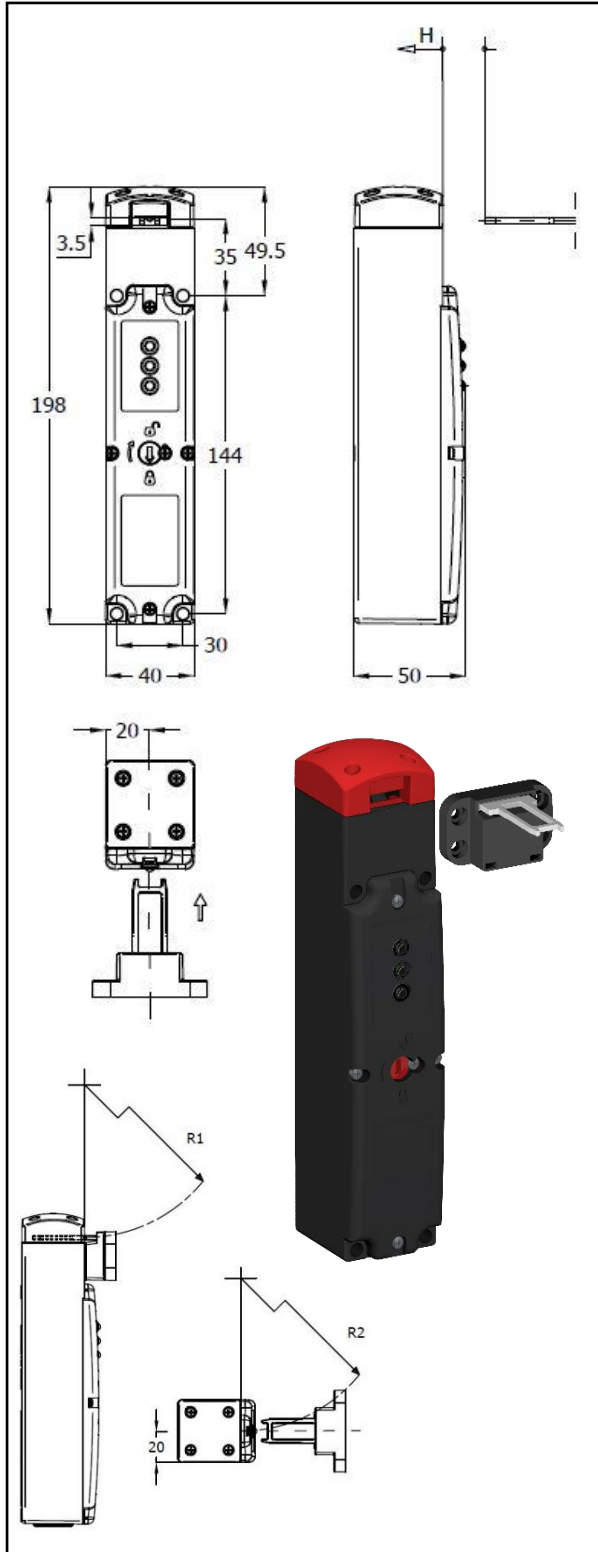

**Electrical data of the device**

Electrical data of the output contacts 21-22 and 41-42		
Insulation voltage Ui	250V (Pollution degree 3)	
Electrical rating (UL508)	A300 – C300	
Rated short-circuit current Uimp	2.5kV	
Conventional thermal current Ith	10A	
Short-circuit protection	Fuse type gG (gI) – 10A	
Rated operating currents Ue	AC-15 24V - 50/60Hz	10A
	AC-15 230V - 50/60Hz	4A
	CC-13 24V	4A
Linking terminals	M3 with cable clamp plate	
Connection wire section	0.34 ... 1.5 mm <sup>2</sup> (1 or 2)	
Electrical features of the inputs		
Rated operating voltage Ue	24Vcc	
Power supply tolerance	+/- 10%	
Maximum design current	0.5A	
Rated insulation voltage Ui	32V	
Rated impulse voltage	1.5kV	
Connection cable nominal area	0.14 ... 1.5 mm <sup>2</sup>	
Linking terminals	M2 screw terminals	
RFID sensor features		
Switching distance	3mm	
Release distance guaranteed with locked actuator	22mm	
Release distance guaranteed with unlocked actuator	4.5mm	
Switching distance guaranteed	2.5mm	
Maximum switching frequency	1Hz	
Sensor reading time	1s	
Actuator adjustment		
Insertion depth H	30mm	
Insertion radius R1	800mm	
Insertion radius R2	600mm	

**FCC Recommendations for USA market**

This device complies with Part 15 of the FCC Rules. Operation is subject to the following two conditions:

- (1) this device may not cause harmful interference, and
- (2) this device must accept any interference received, including interference that may cause undesired operation.

No changes shall be made to the equipment without the manufacturer's permission as this may void the user's authority to operate the equipment

**New actuator pairing**

- ① Open the device cover
- ② Give the power supply as specified on this document
- ③ Wait 10 seconds to allow the initialization procedure of the device
- ④ Insert the new actuator inside the operating head
- ⑤ Push with a tool the button below the hole visible on the superior part of the device, to the right of signaling LED
- ⑥ Wait for the green KEY LED to flashing
- ⑦ If the LED KEY remains green the key is correctly recognized, otherwise refer to the problem solving section of this manual.